

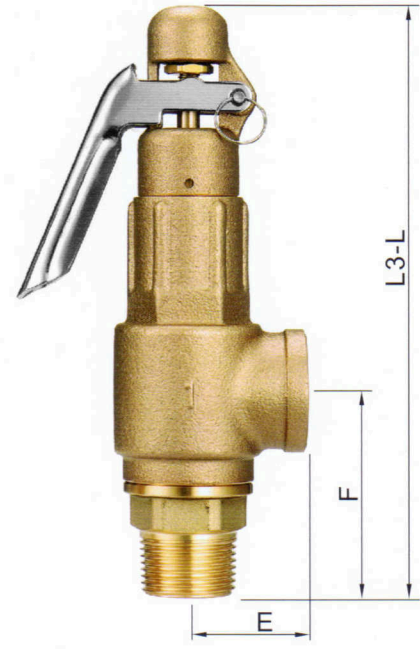

BRONZE SAFETY VALVES

L3 Sealing 1/2"~2"

L3-L Lever 1/2"~2"

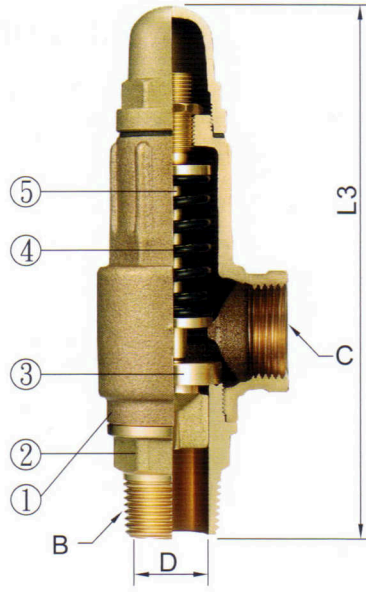
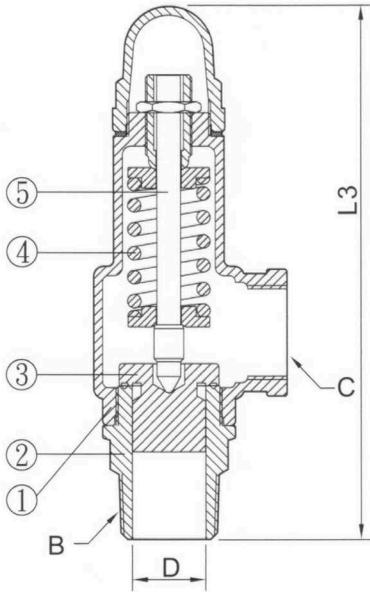

Dimensions

(Sealing)

Unit:mm

(Lever)

Unit:mm

Item Size	Unit:mm								Item Size	Wt. kg	
	L3	Inlet B	Outlet C	Valve seat orifice D	E	F	Lift	Wt. kg			L3-L
1/2"	138	1/2"	1/2"	13	29	50	0.52	0.52	1/2"	161	0.59
3/4"	149	3/4"	3/4"	19	36	58	0.76	0.66	3/4"	172	0.74
1"	181	1"	1"	25	40	70	1.00	1.09	1"	202	1.19
1-1/4"	207	1-1/4"	1-1/4"	32	50	82	1.28	1.90	1-1/4"	222	1.94
1-1/2"	231	1-1/2"	1-1/2"	38	54	93	1.52	2.35	1-1/2"	246	2.39
2"	266	2"	2"	50	67	102	2.00	3.85	2"	282	4.11

General Material

NO.	Parts Name	Model	
		L3 Sealing	L3-L Lever
1	Valve Body	Cast Bronze	
2	Valve Seat	Forging Brass	
3	Disc	Forging Brass	
4	Spring	Steel	
5	Stem	Brass	
Working Pressure		0.3~2 kgf/cm ²	2.1~10 kgf/cm ²
Working Temp		-45 °C~185 °C	
Working Fluid		Noncorrosive Gas、Air、Steam	